



Connectors > PCB Connectors > PCB Headers & Receptacles

PCB Connector Assembly Type: **PCB Mount Header**PCB Mount Orientation: **Vertical**Connector System: **Board-to-Board**Number of Positions: **2**Number of Rows: **1**

Features

Product Type Features

PCB Connector Assembly Type	PCB Mount Header
Connector System	Board-to-Board
Header Type	Breakaway
Connector & Contact Terminates To	Printed Circuit Board

Configuration Features

Connector Contact Load Condition	Fully Loaded
PCB Mount Orientation	Vertical
Number of Positions	2
Number of Rows	1
Board-to-Board Configuration	Parallel

Body Features

Primary Product Color	Green
-----------------------	-------

Contact Features

Contact Mating Area Length	11 mm[.433 in]
PCB Contact Termination Area Plating Material Thickness	2.5 μ m
Mating Tab Width	1.6 mm[.063 in]
Mating Tab Thickness	.8 mm[.031 in]
Contact Underplating Material	Nickel



PCB Contact Termination Area Plating Material	Tin
Contact Base Material	Brass
Contact Mating Area Plating Material	Tin-Lead
Contact Mating Area Plating Material Thickness	3 – 5 μm [118.11 – 196.85 μin]
Contact Type	Pin
Contact Current Rating (Max)	5 A

Termination Features

Rectangular Termination Post & Tail Thickness	.8 mm[.031 in]
Rectangular Termination Post & Tail Width	.9 mm[.035 in]
Termination Post & Tail Length	3.4 mm[.134 in]
Termination Method to Printed Circuit Board	Through Hole - Solder

Mechanical Attachment

Mating Alignment	Without
PCB Mount Retention	Without
Connector Mounting Type	Board Mount

Housing Features

Centerline (Pitch)	3.96 mm[.156 in]
Housing Material	PBT GF

Dimensions

PCB Thickness (Recommended)	1.6 mm[.063 in]
-----------------------------	-----------------

Usage Conditions

Operating Temperature Range	-65 – 105 $^{\circ}\text{C}$ [-85 – 221 $^{\circ}\text{F}$]
-----------------------------	--

Industry Standards

Approved Standards	CSA LR7189, CUL E28476
UL Flammability Rating	UL 94V-0

Packaging Features

Packaging Quantity	100
Packaging Type	Box

Product Compliance

For compliance documentation, visit the product page on [TE.com](#)>

EU RoHS Directive 2011/65/EU	Compliant
------------------------------	-----------







EU ELV Directive 2000/53/EC	Compliant
China RoHS 2 Directive MIIT Order No 32, 2016	No Restricted Materials Above Threshold
EU REACH Regulation (EC) No. 1907/2006	Current ECHA Candidate List: JUNE 2022 (224) Candidate List Declared Against: JUNE 2022 (224) Does not contain REACH SVHC
Halogen Content	Not Low Halogen - contains Br or Cl > 900 ppm.
Solder Process Capability	Wave solder capable to 265°C





Product Compliance Disclaimer

This information is provided based on reasonable inquiry of our suppliers and represents our current actual knowledge based on the information they provided. This information is subject to change. The part numbers that TE has identified as EU RoHS compliant have a maximum concentration of 0.1% by weight in homogenous materials for lead, hexavalent chromium, mercury, PBB, PBDE, DBP, BBP, DEHP, DIBP, and 0.01% for cadmium, or qualify for an exemption to these limits as defined in the Annexes of Directive 2011/65/EU (RoHS2). Finished electrical and electronic equipment products will be CE marked as required by Directive 2011/65/EU. Components may not be CE marked. Additionally, the part numbers that TE has identified as EU ELV compliant have a maximum concentration of 0.1% by weight in homogenous materials for lead, hexavalent chromium, and mercury, and 0.01% for cadmium, or qualify for an exemption to these limits as defined in the Annexes of Directive 2000/53/EC (ELV). Regarding the REACH Regulation, the information TE provides on SVHC in articles for this part number is based on the latest European Chemicals Agency (ECHA) 'Guidance on requirements for substances in articles' posted at this URL: <https://echa.europa.eu/guidance-documents/guidance-on-reach>

Compatible Parts

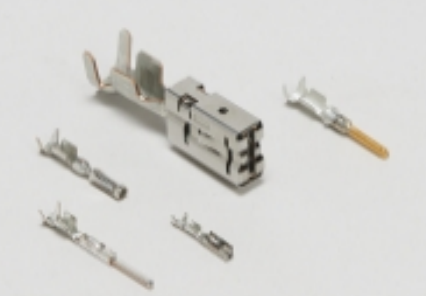
 <p>TE Part # 87995-2 02 MOD1 BDMNT RCPT SR .156CL</p>	 <p>TE Part # 104885-1 MOD 1 RECP STMPD</p>	 <p>TE Part # 87316-7 MOD 1 RECP STMPD</p>	 <p>TE Part # 6-87160-0 09 MOD1 HDR SRST .156CL, ROHS</p>
---	--	---	--

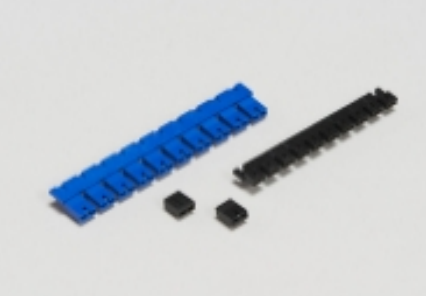
Also in the Series | AMPMODU MOD 1

 <p>Automotive Terminals(6)</p>	 <p>Board-to-Board Connector Contacts (104)</p>	 <p>Board-to-Board Jumpers & Shunts(5)</p>	 <p>Insertion & Extraction Tools(1)</p>
--	--	---	--



PCB Connector Keying(2)

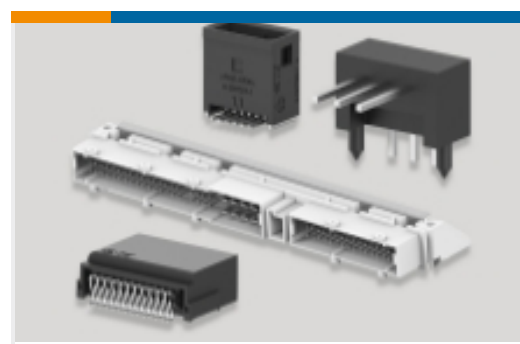

PCB Headers & Receptacles(372)

Wire-to-Board Connector Assemblies
& Housings(44)

Wire-to-Board Connector Contacts(2)

Documents

Product Drawings

2P MOD 1 UNSHROUDED HEADER, ST, TIN

English

CAD Files

3D PDF

English

Customer View Model

[ENG_CVM_826576-2_5.3d_igs.zip](#)

English

Customer View Model

[ENG_CVM_826576-2_5.3d_stp.zip](#)

English

Customer View Model

[ENG_CVM_826576-2_5.2d_dxf.zip](#)

English

By downloading the CAD file I accept and agree to the [Terms and Conditions](#) of use.

Product Environmental Compliance

TE Material Declaration

English

Agency Approvals

UL Report

English